

Compact Engraving Machine

MAGIC™-S3





Compact Engraving Machine, MAGIC™-S3

MAGIC™-S3 is a third-generation multipurpose desktop engraving machine that provides outstanding performance, excellent structural stability and modern design. It is the perfect engraving machine for engraving flat-type materials. It designed with revolutionary features and functions for easy and fast engraving of materials with various forms and sizes.

It is easy and simple to use, and provides a wide range of functions and a powerful performance. It is especially built for multipurpose use, and is designed to make engraving and marking on a variety of products and materials like pet IDs, jewelries, accessories, cosmetic/perfume cases, and industrial name plates and parts, easy and fast.

Key Points

- Allows engraving on acryl, various kinds of plastics, glasses, wood, modeling board, etc.
- Engraves on gold, silver, brass, and all kinds of metals including stainless steel and aluminum.
- Guarantees deep, lasting, high-quality and permanent engravings with a shiny and polished finish using a diamond scribing tool.
- Comes with wide work range, making it possible to engrave on large-scale materials
- Has a built-in camera and a laser for intuitive, easy control of engraving position.
- Automatically measures the height of the material and tool length.
- Enables cost-efficient maintenance with low-cost supplies.
- Light, compact and easy to use and/operate.

Engraving Purposes

- Pendants/pet tag engraving
- Label/signage engraving
- Name plate engraving
- Pen engraving
- Industrial parts/components engraving
- Glass engraving
- Souvenir item engraving
- Promotional gift engraving
- Metal engraving
- Cosmetic/perfume case engraving

Customers

- Makerspace
- Promotional gift shops
- Merch stores
- Art and craft workshops
- Signs shops
- Accessory shops
- Jewelry shops
- Souvenir shops
- Hobbyists

Engraving Materials

- Titanium
- Aluminum, Anodized Aluminum
- Brass
- Precious metals such as gold, silver and platinum
- Steel
- Stainless Steel
- Plated Metal
- Plastic
- Glass
- Others

Product Features

■ Versatile Functions

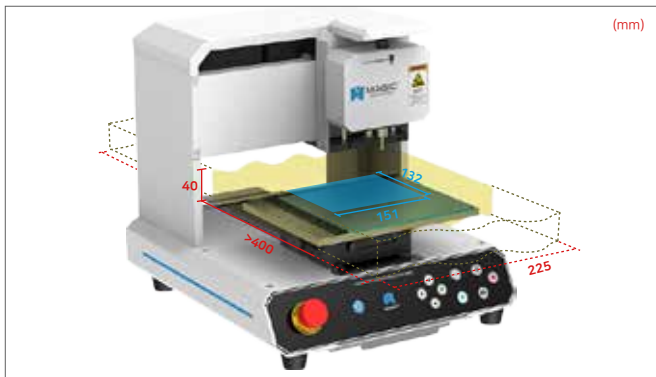

A Wide Work Area

- Equipped with a wider engraving area to enable size expansion of the materials to be engraved.
- Uses a flatbed clamp to firmly hold materials with sizes larger in place, approximately-225mm x 400mm size.



Easy Expansion of Functions

- Provides a detachable clamp to support the expansion of different engraving functions with the use of a single multifunctional pendant clamp.
- The pendant clamp can be transformed into 4 different types of clamps to facilitate engraving for different purposes-depending on the user's intention for use.

■ High Quality Scribing Marking



High-quality Scribe Marking

- Utilizes diamond scribing method with the use of a diamond tool.
- Creates a deep, lasting, permanent mark while maintaining the material's original color.
- Leaves a shiny, smooth, polished finish similar to handcrafted products.



Various Engraving Effects

- Enables application of various effects on engravings to create a more defined, high-quality marks such as: hatching line, diagonal/cross line, contour line, outline, single line and photo marking.

■ Third Generation Multipurpose Desktop Marking Machine

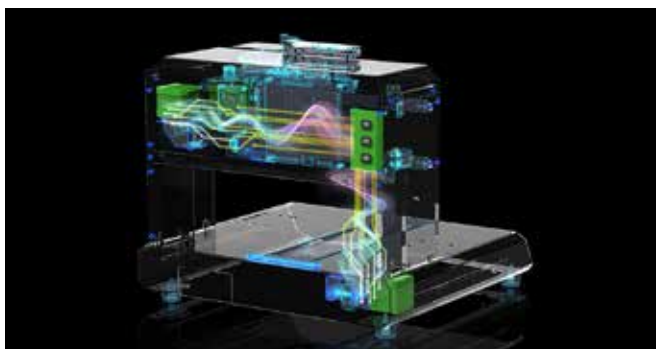

Innovative Functions and Features

- Offers innovative functions and features for easy operation.
- Redesigned and developed following the new and latest technology
- Provides our customers with the most efficient and most advanced engraving machine in the market that produces precise, lasting, high-quality engraving results.

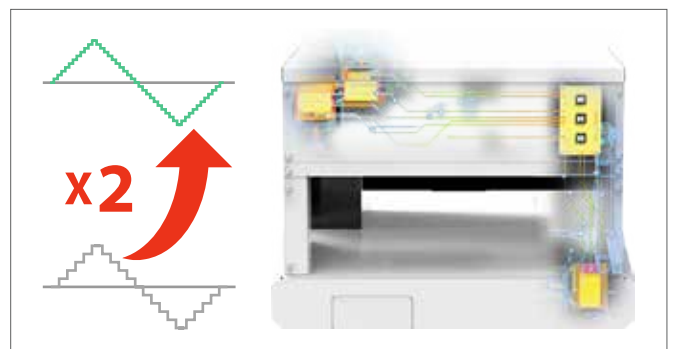

Latest Motor Control System

- Has a motor control system that is two times higher than that of its previous model.
- Produces high-quality, precise and accurate engraving.
- Runs quietly and smoothly to create a favorable working environment.

■ User-friendly Functions

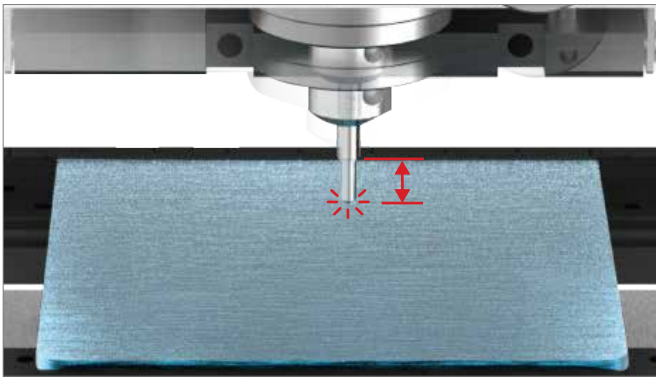

Auto Measurement

- Has an auto measurement function that allow easy use of the machine by automatically measuring the materials and tool.
 - Has auto measurement sensors that measure the length of the tool and detect the height of the material.
- Has an auto tool-setting function where it automatically sets the tool to its origin point.

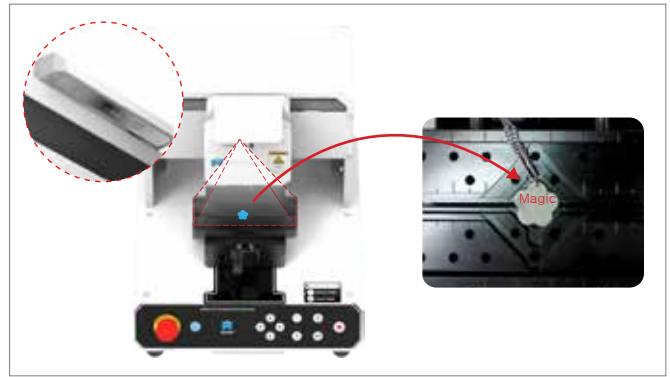

Easy Control of Engraving Position

- Has a built-in camera that enables intuitive operation through a camera to easily position and align the composition (or design) on the workpiece's surface.
- Has a laser pointer that allows users to locate and adjust the engraving position with ease.



High-Speed Marking

- Built for high-speed marking with the use of a diamond tool.
- Ensures high quality marking on various materials at a high speed.



Bluetooth Connection

- Supports Bluetooth connection for easy operation of the machine.
- Compatible with most tablet devices such as Android tablet, iPad and Window tablet.
- Better, more efficient, fast and satisfactory engraving services can be offered by our users to their customers as their customers can directly communicate their requests and preferences to them.

■ Small and Modern Design and a User-friendly Software



Small, Quiet and Modern

- Built small and light for easy installation
- Perfect for any workshops/workspaces due to its modern and sophisticated design.
- Runs quietly to promote a favorable work environment.

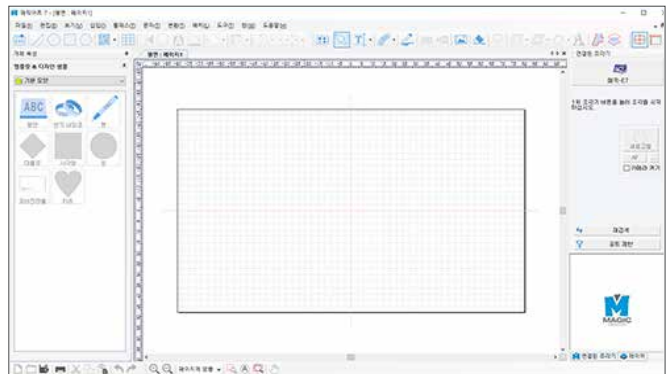

User-friendly Software

- Comes with an easy-to-use software called MagicEngrave™ - a software specifically designed for easy machine operation.
- Enables easy use of the machine for wide-range purposes.
- Enables quick and easy engraving and marking on various materials.

Various Applications

Pendant Engraving



- Engraves letters, logos and patterns on various jewelry products, pet tag tags, military IDs, baby necklaces, souvenirs and promotional gifts.
- Engraves on various materials such as gold, silver, brass, aluminum, stainless steel, titanium, plastic, and glass.

Engraving on Thick Materials

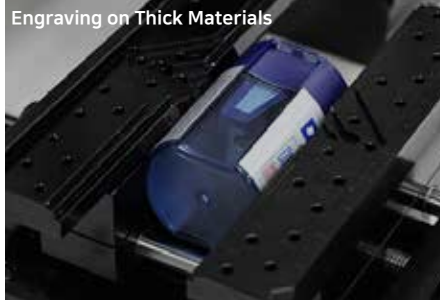

- Engraves materials with different thicknesses.
- Equipped with a height adjustable clamp to adjust to the height of the material.
- Various jigs are used to firmly hold materials with different thicknesses in place.

Engraving on Various Products (for personalization)



- Engraves names, dates and messages on various products like watches (bask case), lighters, or knives for personalization.
- A jig is used to firmly hold materials with different shapes and sizes in place for easy and quick engraving.

Industrial Parts Engraving



- Engraves fonts, sizes and contents on various industrial parts or components.

Engraving on Curved Surfaces



- Engraves on metals with curved surfaces such as bracelet, pen, hip flask, and ball.

Pet Tag Engraving



- Engraves on a wide range of materials like aluminum, plated metal, and plastic for pet tags.

Cosmetic Case Engraving



- Engraves initials, logos and messages on various cosmetic/perfume cases, caps or lids.

Photo Engraving



- Engraves photographs/images using dots.

Industrial Nameplate Engraving



- Creates unfading, permanent, and lasting, engravings on industrial nameplates such as product nameplates and machine nameplates.

Lighter Engraving



- Engraves letters, logos or patterns on lighters made of stainless steel, brass or plated metal.

Military ID marking



- Mark on military IDs made of stainless steel, etc.

Name Tag Engraving



- Engraves letters, logos and patterns on various name tags.

Engraving on Long Materials

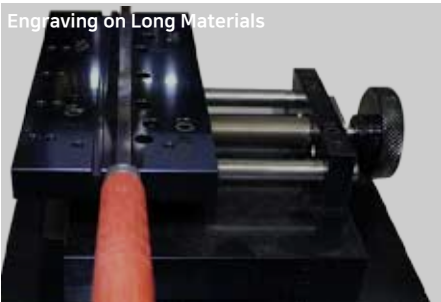

- Engraves on materials with long sizes.
- Has an open front and back to allow accommodation of materials with longer sizes.

Pen Engraving



- Engraves on pens with different forms and lengths.
- A pen clamp is used to firmly hold pens with different sizes and forms in place during engraving process.

Engraving on Various Products



- Engraves names, dates and messages on various products with ease.
- A jig to is used to firmly hold materials with different shapes and sizes in place for easy and quick engraving.

Technical Specifications

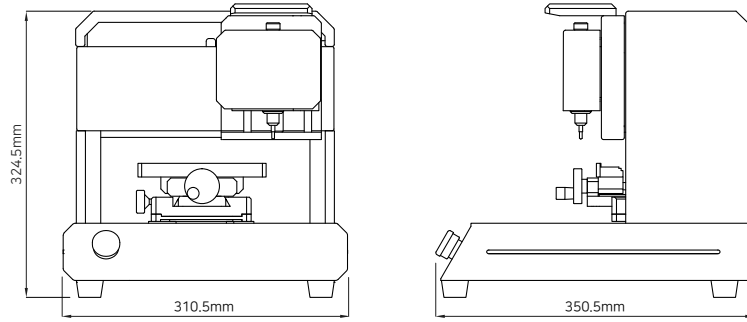

Model	MAGIC™-S3	Weight	43.21 lb
Size	310.5mm(W) x 350.5mm(D) x 324.5mm(H)	Voltage	AC 100~240V, 50Hz/60Hz
XYZ axis stroke	153mm(X) x 134mm(Y) x 38.5mm(Z)	Power consumption	24W
Max material height	40mm	Flat clamp engraving area	145mm x 120mm x 38.5mm
Temperature	15 ~ 40°C	Humidity	10 ~ 90%
Bluetooth	Bluetooth BLE(Bluetooth 5.0) / Communication Range : Class 2(32.8ft) / Tx Output : MAX +4dBm / Frequency Band : 2.4 GHz		

Device Options

Flatbed clamp



To hold materials like plates, blocks and various materials with different forms, sizes, and thicknesses, in place.

Curved tag adapter



To firmly hold the back of the curved material in place. (Curved pendant, chain bracelet, etc)

Watch adapter



To firmly hold watch in place.

Cutlery clamp



To firmly hold spoons in place.

Pin clamp



To hold materials with different shapes in place.

Bracelet adapter



To firmly hold bracelets in place.

Bar necklace adapter



To firmly hold narrow pendant (2~3mm) in place.

Samples

