

Multipurpose Desktop Engraving Machine
MAGIC™-E4





Multipurpose Flatbed Engraving Machine, MAGIC™-E4

MAGIC™-E4 is a 3rd generational multipurpose desktop engraving machine that is built to produce excellent, high-quality and precise engraving, cutting, and marking results on various materials with different forms and sizes. It offers innovative features to make engraving operations simple and easy. It is built with a reliable structural stability to promote the safe use of the machine.

It is designed for easy and multipurpose use. It comes with an easy-to-use software that enables easy and fast engraving operations. Its multifunctional system is designed to engrave on various products like labels, name tags, and nameplates, and various materials like acryl and brass. It engraves and marks on signages, souvenirs, promotional gifts, industrial nameplate/parts, etc. It also facilitates cutting and machining of acryl, wood, modeling board, etc. Overall, this machine provides a wide range of functions and features to satisfy our customers' needs

Key Points

- Allows engraving on acryl, various kinds of plastics, glasses, wood, modeling board, etc.
- Engraves on gold, silver, brass, and all kinds of metals including stainless steel and aluminum.
- Cuts gold, silver, brass, aluminum, acryl, various kinds of plastics, wood, etc.
- Carves 2.5D by relief laser.
- Comes with wide work range, making it possible to engrave on large-scale materials
- Supports different engraving tools such as endmill, V-cutter, and scribing tools.
- Has a built-in camera and a laser for intuitive, easy control of engraving position.
- Automatically measures the height of the material and tool length.
- Enables cost-efficient maintenance with low-cost supplies.
- Light, compact and easy to use and/operate.

Engraving Materials

- Precious metals such as gold, silver and platinum
- Titanium
- Aluminum, Anodized Aluminum
- Brass
- Steel
- Stainless Steel
- Plated Metal
- Plastic
- Glass
- Others

Engraving Purposes

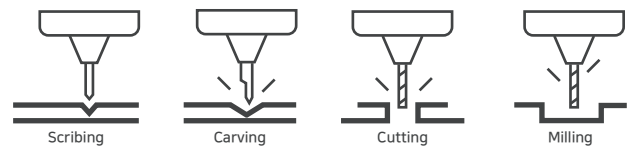

- Logo/character/image/drawing/pattern engraving
- Metal/acryl/wood board cutting
- 2.5D relief carving
- Pendants/pet tag engraving
- Label/signage engraving
- Metal engraving
- Glass engraving
- Silicon mold machining
- Cosmetic/perfume case engraving
- Souvenir item engraving
- Promotional gift engraving
- Name plate engraving
- Industrial parts/components engraving

Customers

- Makerspace
- Promotional gift shops
- Merch stores
- Art and craft workshops
- Signs shops
- Accessory shops
- Jewelry shops
- Souvenir shops
- Hobbyists

■ 3rd generational multipurpose desktop engraving machine

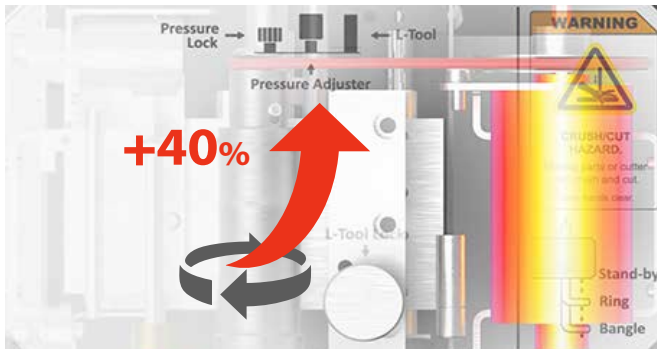

Stronger and Higher-speed Cutting Performance

- Equipped with a more powerful spindle motor with a spinning capacity of 15,000RPM.
- Compared to its previous models, its cutting force is approximately 40% stronger, enabling a higher-speed cutting performance, improved cross section quality, and long lasting, durable tools.

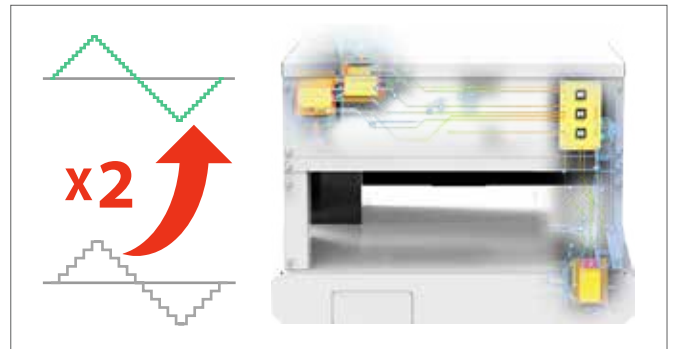

Higher Resolution and Quality

- Has a higher resolution and quality.
- Compared to its previous models, its resolution and quality are made two times higher to enable a quiet machine operation, and a precise, accurate and high-quality engraving on various products.

■ Various Engraving Methods



Various Engraving Methods

- Performs various engraving methods such as: cutting, milling, photo marking, halftone engraving, drilling, 2.5D relief carving and V-carving.



Various Engraving Effects

- Enables application of various effects on engravings to create a more defined, high-quality marks such as: hatching line, diagonal/cross line, contour line, outline, single line and photo marking.

■ Versatile Application



A Wide Work Area

- Equipped with a wider engraving area to enable size expansion of the materials to be engraved.
- Uses a flatbed clamp to firmly hold materials with sizes larger in place, approximately--240mm x 180mm size.

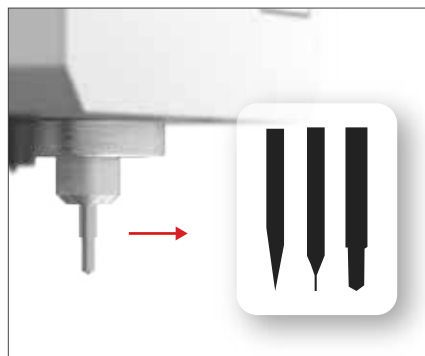

Equipped with Various Tools

- Uses a variety of tools to facilitate various purposes for engraving, cutting, and marking.
- Has a built-in spindle rotation that rotates a tool to process the material during engraving operation.
- Provides a diamond tool that is used to engrave to scribe mark on different products.
- Provides other tools that are used to enhance marking effects.

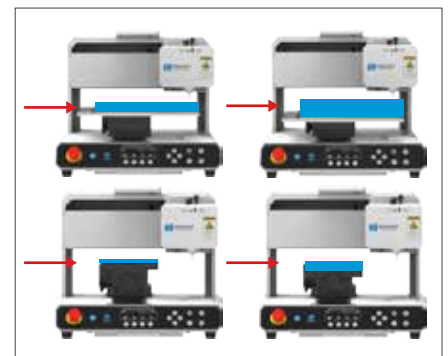

Easy Expansion of Functions

- Provides a detachable clamp to support the expansion of different engraving functions with the use of a single multifunctional pendant clamp.
- The pendant clamp can be transformed into 4 different types of clamps to facilitate engraving for different purposes--depending on the user's intention for use.

Convenient Functions for Easy and Quick Marking for Everyone

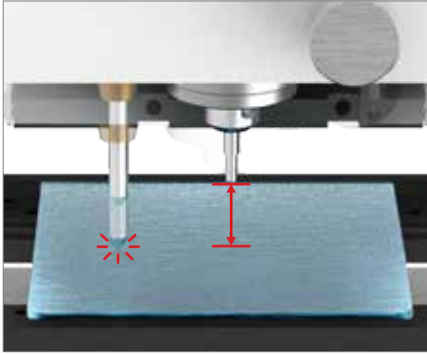

Auto Measurement

- Has an auto measurement function that allow easy use of the machine by automatically measuring the materials and tool.
- Has auto measurement sensors that measure the length of the tool and detect the height of the material.
- Has an auto tool-setting function where it automatically sets the tool to its origin point.

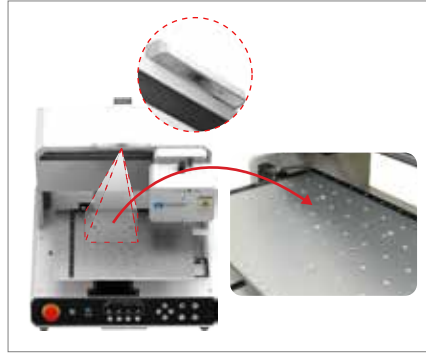

Easy Control of Engraving Position

- Has a built-in camera that enables intuitive operation through a camera to easily position and align the composition (or design) on the workpiece's surface.
- Has a laser pointer that allows users to locate and adjust the engraving position with ease.



Bluetooth Connection

- Supports Bluetooth connection for easy operation of the machine.
- Compatible with most tablet devices such as Android tablet, iPad and Window tablet.
- Better, more efficient, fast and satisfactory engraving services can be offered by our users to their customers as their customers can directly communicate their requests and preferences to them.

Easy and User-Friendly Design and Software for Anyone



Small, Quiet and Modern

- Built small and light for easy installation
- Perfect for any workshops/workspaces due to its modern and sophisticated design.
- Runs quietly to promote a favorable work environment.

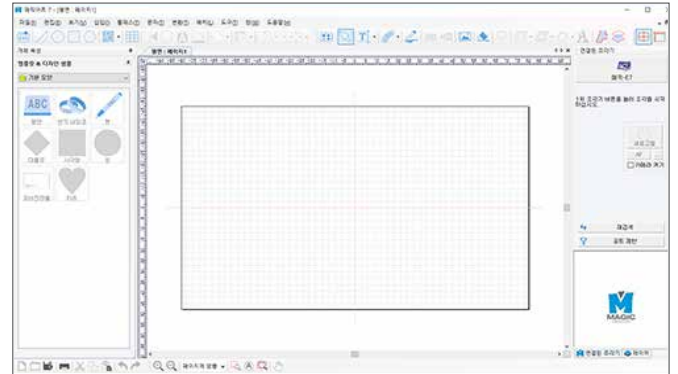

User-friendly Software

- Comes with an easy-to-use software called MagicEngrave™ - a software specifically designed for easy machine operation.
- Enables easy use of the machine for wide-range purposes.
- Makes engraving, cutting and marking of materials simple and fast.

Samples



Various Applications

Plate-type Material Engraving

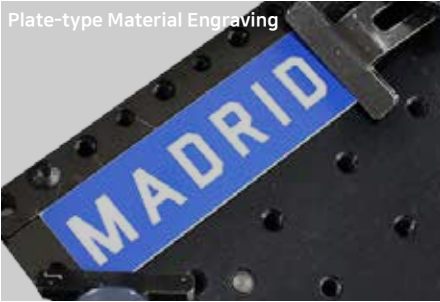

- Engraves letters, logos and patterns in a set depth using various tools such as endmill and V-cutter
- Engraves on various materials like wood, acryl, modeling board, aluminum, and brass.

Plate Cutting



- Cuts different materials such as gold, silver, brass, aluminum, wood, acryl, plastics, and engraving waxes into desired forms.
- Cuts various materials to create labels or signages, name necklaces and other jewelries/accessories.

Pendant Engraving



- Engraves letters, logos and patterns on various jewelry products, pet tag tags, military IDs, baby necklaces, souvenirs and promotional gifts.
- Engraves on various materials such as gold, silver, brass, aluminum, stainless steel, titanium, plastic, and glass.

Name Tag Engraving



- Engraves letters, logos and patterns on various name tags.

2.5D Relief Carving

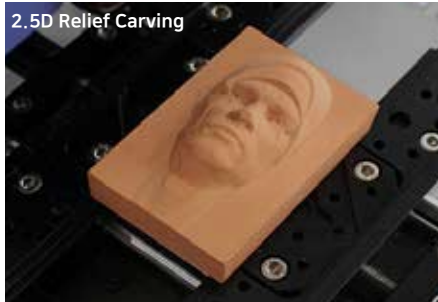

- Carves 2.5D relief on modeling boards, wood, acryl and plastics with the use of a 3D model and a CAM program.

Industrial Nameplate Engraving



- Creates unfading, permanent, and lasting, engravings on industrial nameplates such as product nameplates and machine nameplates.

Engraving on Curved Surfaces



- Engraves on materials with curved surfaces such as bracelet, pen, hip flask, and ball.

Cosmetic Case Engraving



- Engraves initials, logos and messages on various cosmetic/perfume cases, caps or lids.

Photo Engraving



- Engraves photographs/images using dots.

Military ID Tag Engraving



- Engraves on military IDs/soldier tags made of stainless steel.

Engraving on Long Materials

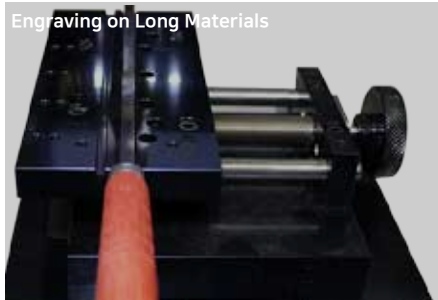

- Engraves on materials with long sizes.
- Has an open front and back to allow accommodation of materials with longer sizes.

Pet Tag Engraving



- Engraves on a wide range of materials like aluminum, plated metal, and plastic for pet tags.

Engraving on Thick Materials

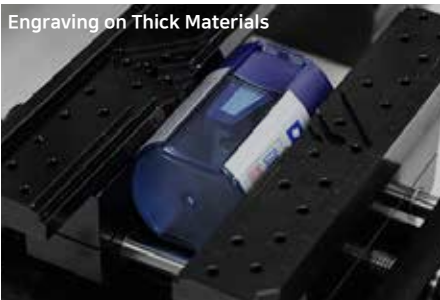

- Engraves on materials with different thicknesses.
- Equipped with a height adjustable clamp to adjust to the height of the material.
- Various jigs are used to firmly hold the materials in place during engraving process.

Pen Engraving



- Engraves on pens with different forms and lengths.
- A pen clamp is used to hold pens with different sizes and forms in place during engraving process.

Engraving on Various Products (for personalization)



- Engraves names, dates and messages on various products like watches (back case), lighters, or knives for personalization.
- A jig is used to firmly hold materials with different shapes and sizes in place for easy and quick engraving.

Technical Specifications

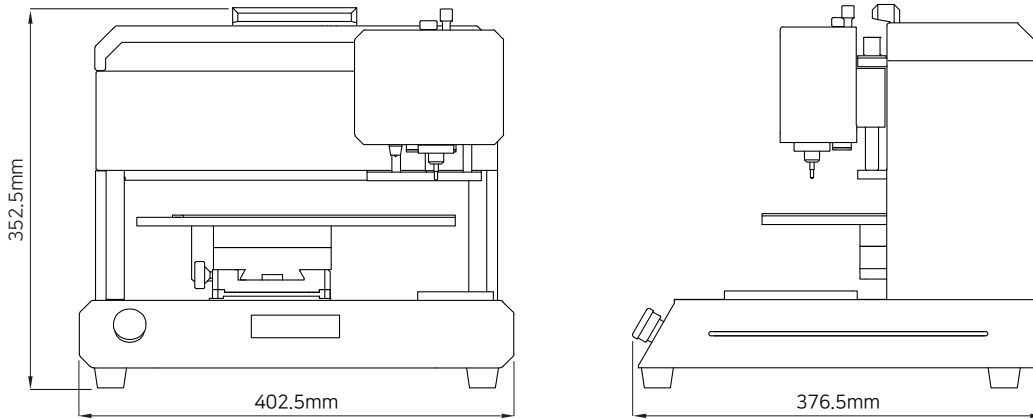

Model	MAGIC™-E4	Weight	55.11 bl
Size	402.5mm(W) x 376.5mm(D) x 352.5mm(H)	Voltage	AC 100~240V, 50Hz/60Hz
XYZ axis stroke	244mm(X) x 179mm(Y) x 40mm(Z)	Power consumption	46W
DC Motor Output	38W	Flat engraving area	241mm x 158mm x 38.5mm
Max material height	60mm	Spindle Motor RPM	MAX 15,000RPM
Temperature	0 ~ 40°C	Humidity	10 ~ 85%
Bluetooth	Bluetooth BLE(Bluetooth 5.0) / Communication Range : Class 2(32.8ft) / Tx Output : MAX +4dBm / Frequency Band : 2.4 GHz		

Options

- Pendant Clamp

A versatile jaw-type clamp that firmly holds materials with different sizes and forms in place like pendants, plates, etc.

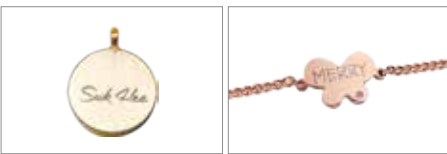

- Cutting Clamp

A clamp that firmly holds the materials in place while the machine cuts the materials (which requires the use of cutting oil during the process).



- Dust Collector(CP-261)

A device that sucks in chips and dust generated from engraving acrylic, modeling board, etc.



- L-type Jig

A clamp that firmly holds a watch in place while marking on its back case.



- Spoon Clamp

A cutlery clamp that firmly holds long and asymmetrical materials in place like spoons, forks, and chopsticks.



- Clamp Pin

A clamp pin is used to firmly hold objects/materials with different thickness and/or irregular shapes in place-that a basic clamp may not hold like pendants, accessories, or pens.

